

- 1
- 2
- 3
- 4
- 5
- 6
- 7
- 8
- 9
- 10
- 11
- 12
- 13
- 14
- 15

MATERIAL

Glass-fibre reinforced polyamide based (PA) technopolymer, black colour, glossy finish.

BOSS CAP

Acetal resin based (POM) technopolymer, light-grey colour, push-fit assembly, removable by pressing on the outer edge (ELESA original design).

STANDARD EXECUTIONS

Black-oxide steel boss, H7 reamed hole.
Assembly by means of a keyway or a transversal pin in the semi-machined hole f or a set screw (redrill and tap hole f).

- **IZN.380**: plain knob.
- **IZN.380+K**: knob with matte anodised aluminium flange, triangular black index.
- **IZN.380+FGS**: knob with matte anodised aluminium flange, black graduation (marks and numbers).
- FGS 10/40 = 40 marks, numbering from 0 to 9 increases as the knob is turned clockwise.
- FGS 10/100 = 100 marks, numbering from 0 to 9 increases as the knob is turned clockwise.

For other numbering (see Graduations on page 533).

ACCESSORIES ON REQUEST

Ball and spring for clicking operation to be fitted in the assembly hole for knobs with diameter D ≥ 48 mm, available only for IZN.380, (see ball and spring MS. page 543).

SPECIAL EXECUTIONS ON REQUEST

On the surface of the boss cap words, marks, graphic symbols, etc... can be tampprinted in colours.



ELESA Original design **if79**

Conversion Table	
1 mm = 0.039 inch	
D	
mm	inch
32	1.26
37	1.46
42	1.65
48	1.89
52	2.05
58	2.28
63	2.48
80	3.15

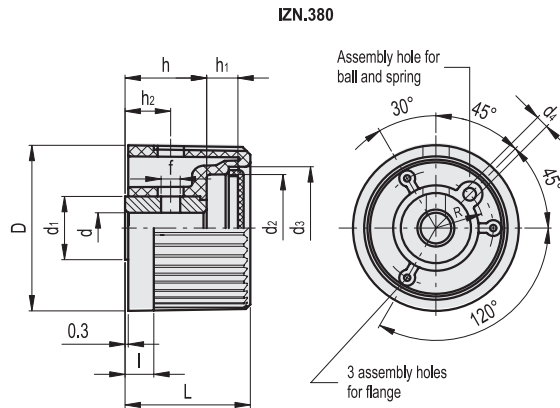

IZN.380

METRIC

Code	Description	D	dH7	L	l	d1	d2	d3	d4	h	h1	h2	f	R	⚖
29001	IZN.380/32 A-6	32	6	26	5	15	19	21	-	16	8	9	3	-	28
30001	IZN.380/36 A-6	37	6	29	6	15	25	27	-	16	10	10	3	-	34
30101	IZN.380/40 A-8	42	8	32	7	18	29	31	-	17	11	11	4	-	48
30201	IZN.380/45 A-8	48	8	35	8	22	32	34	3.2	22	10	14	4	14	86
30301	IZN.380/50 A-10	52	10	39	9	22	37	39	4.2	22	13	14	4	15	90
30331	IZN.380/50 A-12	52	12	39	9	22	37	39	4.2	22	13	14	4	15	85
30401	IZN.380/56 A-12	58	12	41	10	26	42	44	5.2	27	11	16	5	17	130
30451	IZN.380/63 A-10	63	10	44	11	26	48	50	6.2	30	10	16	5	19	155
30466	IZN.380/63 A-12	63	12	44	11	26	48	50	6.2	30	10	16	5	19	150
30501	IZN.380/63 A-14	63	14	44	11	26	48	50	6.2	30	10	16	5	19	145
30601	IZN.380/80 A-16	80	16	48	12	26	59	62	6.2	30	13	17	5	24	175

Assembly examples

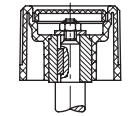

Assembly by means of a keyway

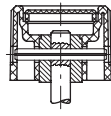

Assembly by means of a transversal pin

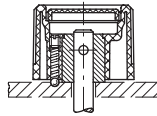

Assembly by means of a transversal pin and ball with adjustable pressure spring

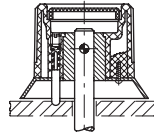

Assembly by means of a transversal pin and adjustable pressure spring plunger

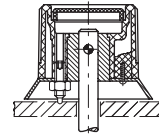

Assembly by means of a transversal pin and plunger with locknut

IZN.380+K

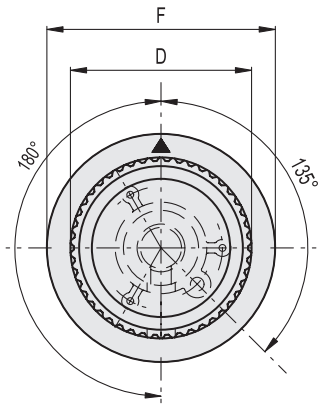

IZN.380+FGS

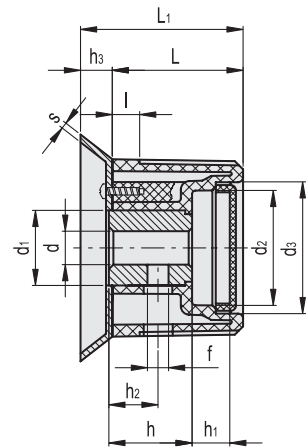

Conversion Table 1 mm = 0.039 inch	
D	
mm	inch
32	1.26
37	1.46
42	1.65
48	1.89
52	2.05
58	2.28
63	2.48
80	3.15

IZN.380+K

METRIC

Code	Description	D	dH7	L	L1	F	l	d1	d2	d3	h	h1	h2	h3	f	s	⚖
29021	IZN.380/32 A-6+K	32	6	26	32	38	5	15	19	21	16	8	9	6	3	0.8	32
30021	IZN.380/36 A-6+K	37	6	29	36	45	6	15	25	27	16	10	10	7	3	1	40
30121	IZN.380/40 A-8+K	42	8	32	39	50	7	18	29	31	17	11	11	7	4	1	54
30221	IZN.380/45 A-8+K	48	8	35	43	55	8	22	32	34	22	10	14	8	4	1	93
30321	IZN.380/50 A-10+K	52	10	39	48	63	9	22	37	39	22	13	14	9	4	1	100
30421	IZN.380/56 A-12+K	58	12	41	52	70	10	26	42	44	27	11	16	9	5	1	140
30461	IZN.380/63 A-10+K	63	10	44	57	78	11	26	48	50	30	10	16	13	5	1	172
30476	IZN.380/63 A-12+K	63	12	44	57	78	11	26	48	50	30	10	16	13	5	1	167
30521	IZN.380/63 A-14+K	63	14	44	57	78	11	26	48	50	30	10	16	13	5	1	162

IZN.380+FGS

Code	Description	D	dH7	L	L1	F	l	d1	d2	d3	h	h1	h2	h3	f	s	⚖
29016	IZN.380/32 A-6+FGS-10/40	32	6	26	32	38	5	15	19	21	16	8	9	6	3	0.8	32
30016	IZN.380/36 A-6+FGS-10/40	37	6	29	36	45	6	15	25	27	16	10	10	7	3	1	40
30116	IZN.380/40 A-8+FGS-10/40	42	8	32	39	50	7	18	29	31	17	11	11	7	4	1	54
30216	IZN.380/45 A-8+FGS-10/100	48	8	35	43	55	8	22	32	34	22	10	14	8	4	1	93
30316	IZN.380/50 A-10+FGS-10/100	52	10	39	48	63	9	22	37	39	22	13	14	9	4	1	100
30416	IZN.380/56 A-12+FGS-10/100	58	12	41	52	70	10	26	42	44	27	11	16	11	5	1	140
30458	IZN.380/63 A-10+FGS-10/100	63	10	44	57	78	11	26	48	50	30	10	16	13	5	1	172
30473	IZN.380/63 A-12+FGS-10/100	63	12	44	57	78	11	26	48	50	30	10	16	13	5	1	167
30516	IZN.380/63 A-14+FGS-10/100	63	14	44	57	78	11	26	48	50	30	10	16	13	5	1	162



Control elements